

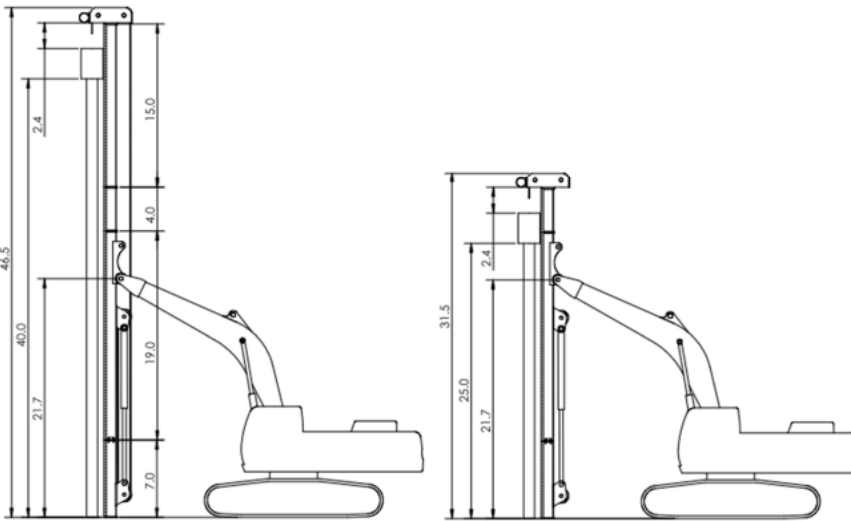

Excavator Mounted Lead System for 35 Ton Excavator

Features

- 8,000 lb Drop Hammer
- 4,000 lb Drop Hammer Available
- (A Driven Pile is a Tested Pile!)
- Designed to drive up to 40' Sections HP12x74/ 310x110
- Low Headroom Configuration Available
- Sheeting Anvil Option Available



Base Machine	35 US ton	31.75 tonne
Lead Only Weight	5,000 lbs	2,267kg
Weight of Drop Hammer & Anvil	8,850 lbs	4,014 kg
Total Lead Length (STD)	46-ft 6-in	14.17 m
Pile Line Winch - (single part)	5,000 lbs nominal lift capacity	22.24kN
Drop Hammer Mass	8,000 lbs	3,628 kg
Standard Anvil Mass	850 lbs	386 kg
Sheeting Anvil Mass * Sold Separately	1,400 lbs	635 kg
Potential Energy (7ft Drop)**	56,055 ft-lbs	76 kJ

©Bermingham 2017 - Photos: Bermingham photo library

bfssales@berminghammer.com

* Geotechnical conditions may alter the pile proving capacity

**4 ft stroke is operational stroke, 7 ft stroke should only be used for pile proving

www.berminghammer.com

